

Games, Markets & Algorithms:

Reasoning about an
Interconnected World



Kevin Leyton-Brown
Computer Science Department
University of British Columbia

Algorithmic Game Theory



*...an interface between
Computer Science
& Microeconomics*



- **Defining characteristic:**
 - tackling both computational and incentive problems that arise when multiple self-interested agents interact
- Constraints from **Game Theory/Microeconomics**
 - Agents self-motivated
- Constraints from **Computer Science**
 - Not enough time, storage, bandwidth, ...

Game Theory

- Mathematical study of interaction between **self-interested, rational** agents
- **Game**
 - players/agents
 - actions
 - payoffs
- **Key questions:**
 - how should we expect players to act?
 - how can interactions be structured to yield desirable behaviour?



What's all the excitement about?

coursera

Courses

Universities

About ▾

Kevin Leyton... ▾

Stanford



a place of mind

THE UNIVERSITY OF BRITISH COLUMBIA

Game Theory

Kevin Leyton-Brown, Matthew O. Jackson and Yoav Shoham

The course covers the basics: representing games and strategies, the extensive form (which computer scientists call game trees), repeated and stochastic games, coalitional games, and Bayesian games (modeling things like auctions).

Previous Session:

Jan 7th 2013 (7 weeks long) [View class archive](#)

Workload: 5-7 hours/week

About the Course

Popularized by movies such as "A Beautiful Mind", game theory is the mathematical modeling of strategic interaction among rational (and irrational) agents. Beyond what we call 'games' in common language, such as chess, poker, soccer, etc., it includes the modeling of conflict among nations, political campaigns, competition among firms, and trading behavior in markets such as the NYSE. How could you begin to model eBay, Google keyword auctions, and peer to peer file-sharing networks, without accounting for the incentives of the people using them? The course will provide the basics: representing games and strategies, the extensive form (which computer scientists call game trees), Bayesian games (modeling things like auctions), repeated and stochastic games, and more. We'll include a variety of examples including classic games and real-world applications.



Watch intro video



1,442

4.4k

9.4k

Tweet

+1

Like

About the Instructors



Kevin Leyton-Brown
The University of British Columbia



Matthew O. Jackson
Stanford University



Yoav Shoham
Stanford University



REASONING ABOUT LARGE GAMES

Describe algorithms for finding behavioral profiles in which “everybody wins” in arbitrary, large-scale strategic interactions, like the geographical distribution of Car2Go vehicles or coffee shops.

Game Theory

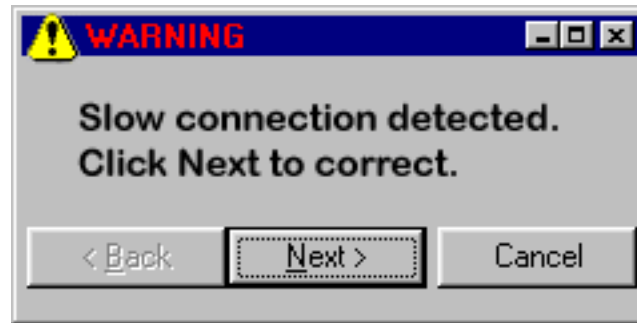

- Should you send your packets using **correctly**-implemented TCP (which has a “backoff” mechanism) or using a **defective** implementation (which doesn’t)?
- Consider this situation as a **two-player game**:
 - both use a correct implementation: both get 1 ms delay
 - one correct, one defective: 4 ms delay for correct, 0 ms for defective
 - both defective: both get a 3 ms delay.

Analyzing Games

- TCP backoff game is a Prisoner's Dilemma
 - both players have a dominant strategy: **defective**
 - if player 2 plays C, D is player 1's best response
 - if player 2 plays D, D is player 1's best response
 - likewise for player 2
 - **dominant strategy**: best response doesn't depend on the other player's action
- Not all games are so simple to analyze
 - the best thing for one player to do can **depend on what the other player does**
 - rock-paper-scissors
 - poker
- What can we say about such games?

	<i>C</i>	<i>D</i>
<i>C</i>	-1, -1	-4, 0
<i>D</i>	0, -4	-3, -3

Game Theory

- Key insight:
 - don't just think about single players' actions
 - find strategy profiles where all players **simultaneously** play best responses
- Such a strategy profile is called a **Nash equilibrium**
 - at least one Nash equilibrium exists in every finite game
 - as long as agents are allowed to **randomize** their strategies
 - best known algorithms for finding Nash equilibrium require **exponential time**

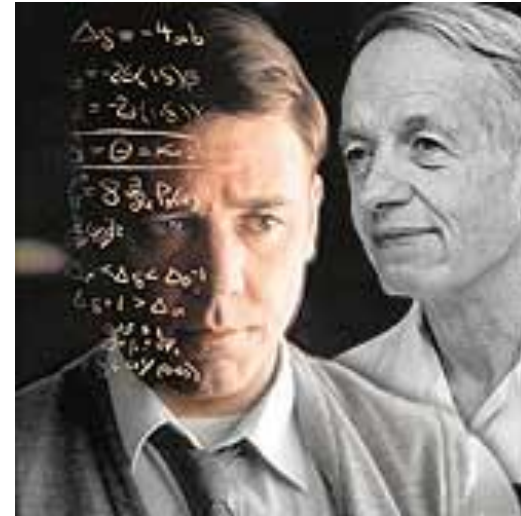

The Kind of Games Often Studied

- The analysis of such 2 x 2 games has proven surprisingly interesting, and has had a **profound impact** both on our understanding of strategic situations and popular culture
 - e.g., Google “**dark knight** game theory”;
“**Strangelove** game theory”



The Kind of Games We'd Like to Study

- When we use game theory to **model real systems**, we'd like to consider games with more than two agents and two actions
- **Some examples** of the kinds of questions we would like to be able to answer:
 - How will heterogeneous users route their traffic in a network?
 - How will advertisers bid in a sponsored search auction?
 - Which job skills will students choose to pursue?
 - Where in a city will businesses choose to locate?
- Most GT work is **analytic, not computational**
- What's holding us back?
 - the size of classical game representations **grows exponentially** in the number of players
 - this makes all but the simplest games infeasible to write down
 - even when games can be represented, the best algorithms tend to have **worst-case performance exponential** in the game's size

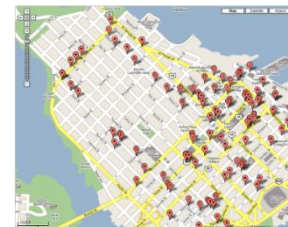
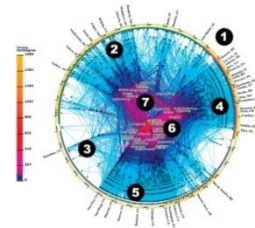

Compact Representations

Research program for advancing the computational analysis of games:

1. find representations that can encode games of interest in **exponentially-less space** than the normal form
 2. find **efficient algorithms** for working with these representations
- **Action Graph Games:** compactly represent games exhibiting context-specific independence, anonymity or additive structure
 - **Generalizes all major, existing compact representations** of simultaneous-move games
 - **Fast algorithms** for computing quantities of interest
 - Nash equilibrium, correlated equilibrium, pure-strategy Nash equilibrium, others...

Coffee Shop Game



[Web](#) [Images](#) [Groups](#) [News](#) [Local](#) [New!](#) [more »](#)

category: Coffee Houses

Search

Search the map

[Find businesses](#)

[Get directions](#)

e.g., "hotels in calgary" or "5000 dufferin street, toronto"

Local

[Print](#) [Email](#) [Link to this page](#)

Search results for **category: Coffee Houses** in this map

- A** [Connoisseurs' Coffee](#)
1075 Georgia Street West, Vancouver, BC V6E 3C9
(604) 683-1486
- B** [Melriches Coffeehouse](#)
1244 Davie Street, Vancouver, BC V6E 1N3
(604) 689-5282
- C** [Hole In The Wall Cappuccino Bar](#)
1030 Georgia Street West, Vancouver, BC V6E 2Y3
(604) 646-4653
- D** [Starbucks Coffee Co](#)
1055 W Georgia, Vancouver, BC V5K 1A1
(604) 685-5882
- E** [Five Roses Bakery Cafe](#)
1220 Bute Street, Vancouver, BC V6E 1Z8
(604) 669-8989
- F** [Starbucks Coffee Co](#)
1095 Howe Street, Vancouver, BC V6Z 1P6
(604) 685-7083
- G** [Uptown Espresso](#)
808 Nelson Street, Vancouver, BC V6Z 2H2
(604) 689-1920
- H** [Caffe Artigiano](#)
763 Hornby Street, Vancouver, BC V6Z 1S2
(604) 696-9222
- I** [Skyline Expresso](#)
900 Howe Street, Vancouver, BC V6Z 2M4
(604) 683-4234
- J** [Fahrenheit Celsius Coffee](#)
1225 Burrard Street, Vancouver, BC V6Z 1Z5
(604) 682-6675
- K** [Chicco Dall Oriente](#)
1504 Robson Street, Vancouver, BC V6G 1C2

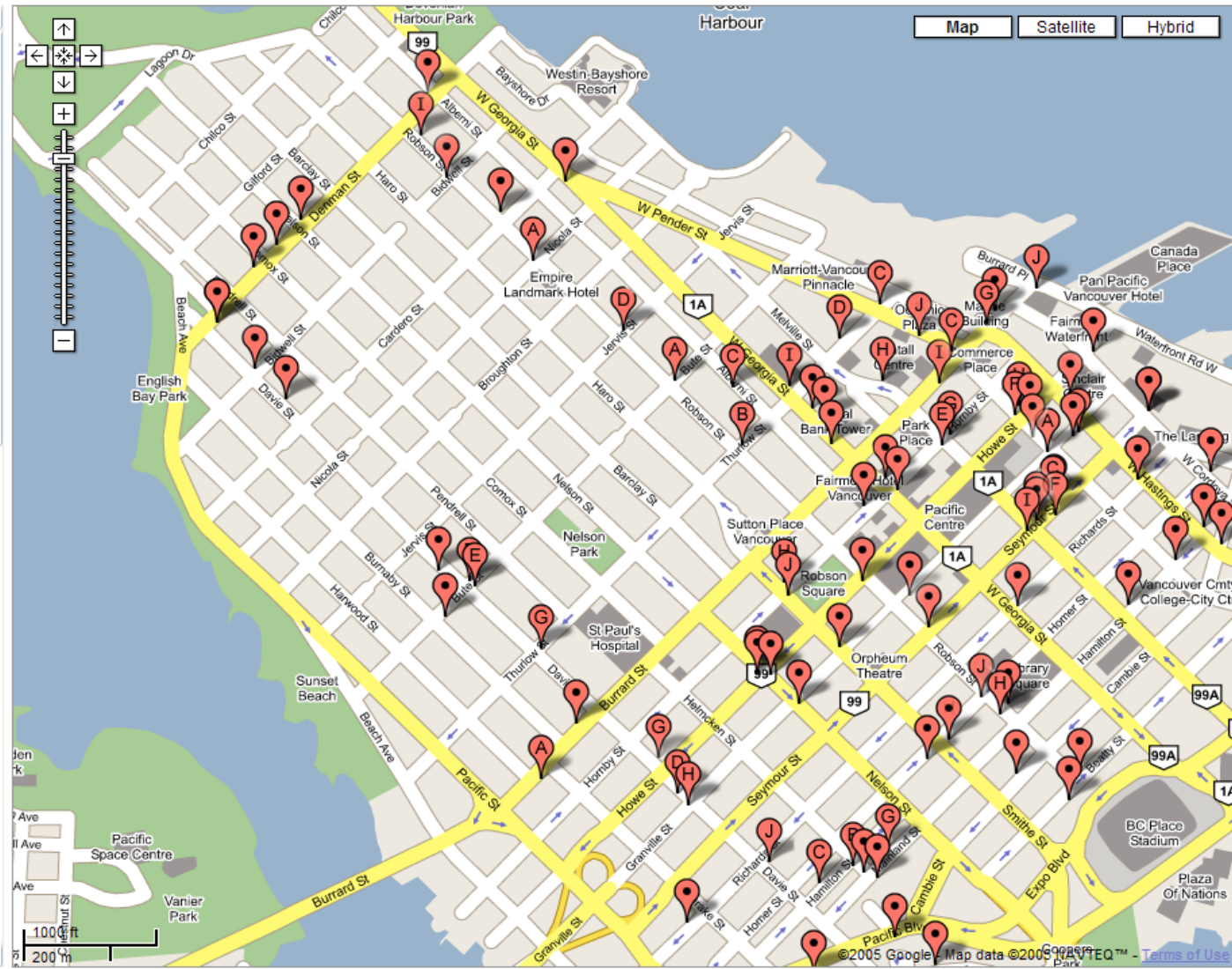

Car2Go Game

[Business customers](#) [car2go Apps](#) [Social Media](#) [car2go Service](#) english ▾ Vancouver ▾



- Home area
- car2go 246
- Parkspots 53
- Gas stations 0
- Reservations 0

🔍

↶ Where am I?

zoom out ⊖

zoom in ⊕

Minimize map ▲

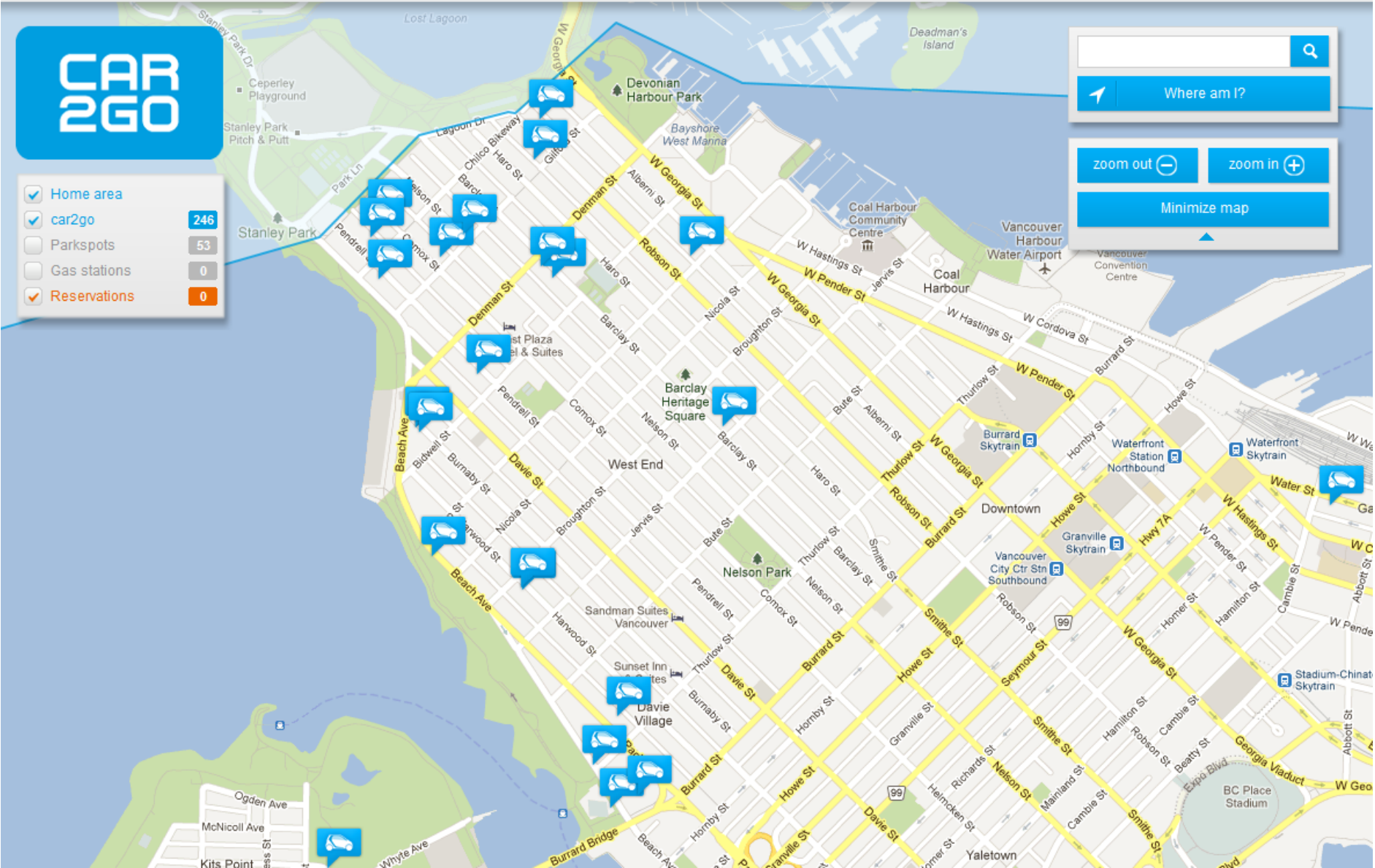

Action-Graph Games

- set of **players**: want to open coffee shops
- **actions**: locations where a shop could be opened
- **utility**: profitability of a location
 - depends only on number of other players who choose same or adjacent location



Computing with AGGs: Complexity

One way to argue for AGGs is to demonstrate theoretical benefits.

Theorem 1 *Given an AGG- \emptyset representation of a game, i 's expected payoff $V_{a_i}^i(s_{-i})$ can be computed in time *polynomial in the size of the representation*. If \mathcal{I} , the maximum in-degree of the action graph, is bounded by a constant, $V_{a_i}^i(s_{-i})$ can be computed in time *polynomial in n* .*

- **Complexity** of our approach:
 $O\left(n^{\mathcal{I}} \text{poly}(n) \text{poly}(|A_{\max}|)\right)$
- **Exponential** speedup vs. standard approach:
 $O\left(|A_{\max}|^{n-1} \text{poly}(n) \text{poly}(|A_{\max}|)\right)$

Experimental Results: Representation Size

We can also argue for AGGs by showing their benefits experimentally.

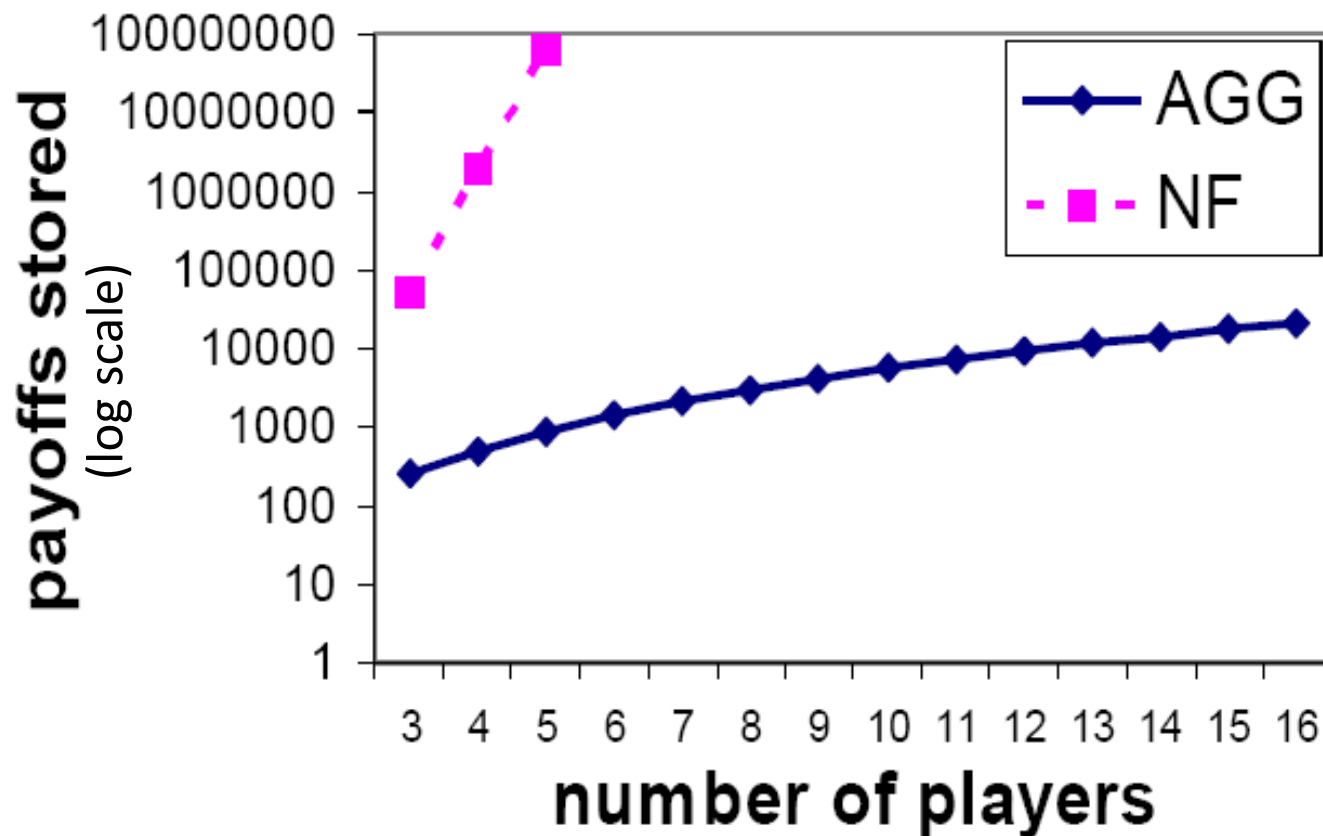

Coffee shop game, 5 x 5 grid

NF grows exponentially; AGG grows polynomially

Experimental Results: Expected Payoff

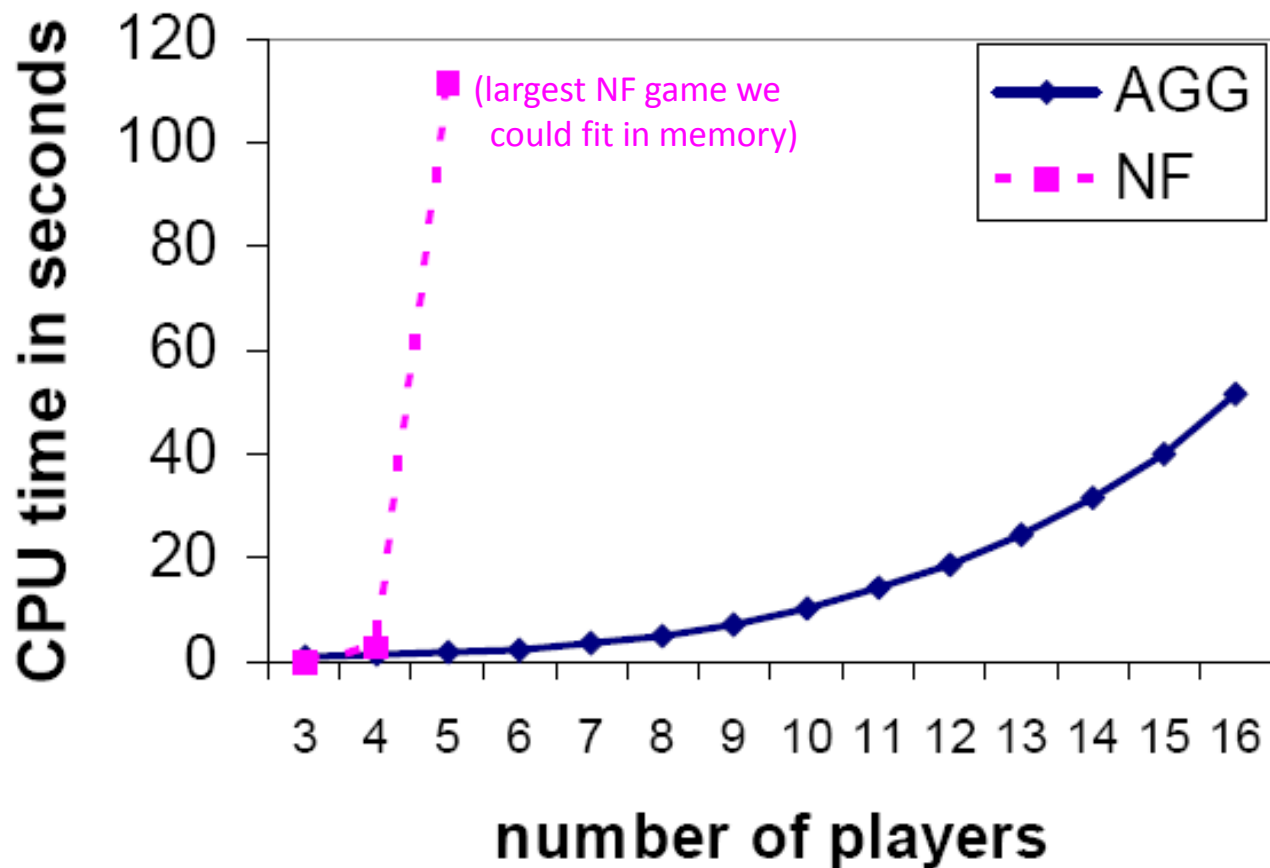

Coffee Shop Game, 5 x 5 grid, 1000 random strategy profiles

NF grows exponentially; AGG grows polynomially



MARKET DESIGN & ANALYSIS

Discuss why Google changed the rules of the market that is responsible for nearly all of its revenue, how market design can help farmers in Uganda, and why algorithmic problems lie at the heart of the FCC's new, multi-billion dollar project to migrate the airwaves from broadcast TV to mobile telephony.

Auctions: why do computer scientists care?

- **Efficient resource allocation**
 - a core interest of computer science
 - auctions solve this problem when agents are self interested
- They're **big** (\$\$\$)
 - and the internet is changing the way they're used

[Back to home page](#)

 Listed in category: [Everything Else](#) > [Metaphysical](#) > [Psychic, Paranormal](#)

Virgin Mary In Grilled Cheese NOT A HOAX ! LOOK & SEE !

Item number: 5535890757

 Bidder or seller of this item? [Sign in](#) for your status

[Email to a friend](#) | [Watch this item](#) in My eBay

Note: This listing is restricted to pre-approved bidders or buyers only.

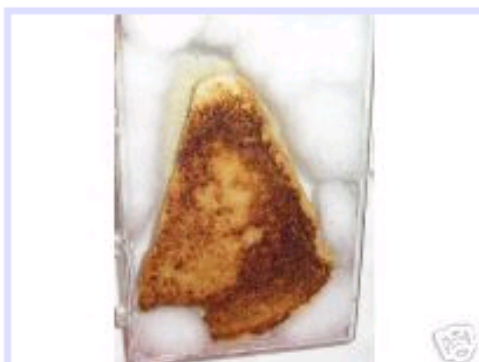
[Email the seller](#) to be placed on the pre-approved bidder/buyer list.

[Larger Picture](#)

 Current bid: **US \$7,600.00**

 Time left: **3 days 23 hours**

 7-day listing
 Ends Nov-22-04
 17:22:07 PST

Start time: Nov-15-04 17:22:07 PST

 History: [4 bids](#) (US \$3,000.00 starting bid)

High bidder: User ID kept private

Seller information

[dltdesigns2002](#) ([47](#) ★)

Feedback Score: 47

Positive Feedback: 96.1%

Member since Jul-03-02 in United States

[Read feedback comments](#)
[Add to Favorite Sellers](#)
[Ask seller a question](#)
[View seller's other items](#)
[Safe Buying Tips](#)

Financing available NEW!

No payments until April, and no interest if paid by April

Auctions: a key application of game theory

- A **broader category** than often perceived
- Generally, auctions are **markets** in which:
 - agents make binding declarations of interest in one or more resources
 - these resources are allocated according to known rules
 - payments to/from agents may be imposed
- Modeled using **game theory**. Some new wrinkles:
 - infinite action space
 - imperfect information about payoffs (other agents' valuations)
- How do sellers choose the **particular auctions** they do?
 - mechanism design (Nobel prize 2007): “inverse game theory”

Second-Price Auctions

- An auction that might initially seem strange: **second-price**
 1. all bidders submit sealed bids
 2. the high bid wins
 3. the winner pays the **second-highest** bid amount
- Compare to something more intuitive: **first-price**
- **Theorem:** it is a dominant strategy in a second-price auction to bid your true value for the good.
- **Proof:**
 - **Case 1:** bidding truthfully **would** make you the high bidder
 - you can't gain by changing your bid
 - **Case 2:** bidding truthfully **would not** make you the high bidder
 - you can't gain by changing your bid

Second-Price Auctions

- **Theorem:** it is a dominant strategy in a second-price auction to bid your true value for the good.

- **Case 1:** bidding truthfully, you're the high bidder

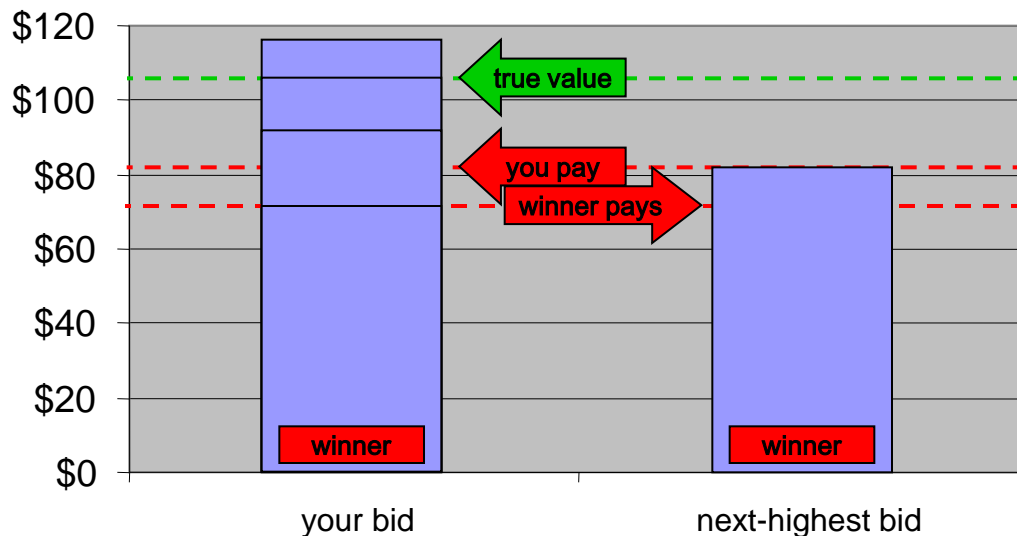

- bid **more**:
 - no difference (still win, pay same)
- bid **less**:
 1. no difference
 2. you lose

Second-Price Auctions

- **Theorem:** it is a dominant strategy in a second-price auction to bid your true value for the good.

- **Case 2:** bidding truthfully, you're **not** the high bidder

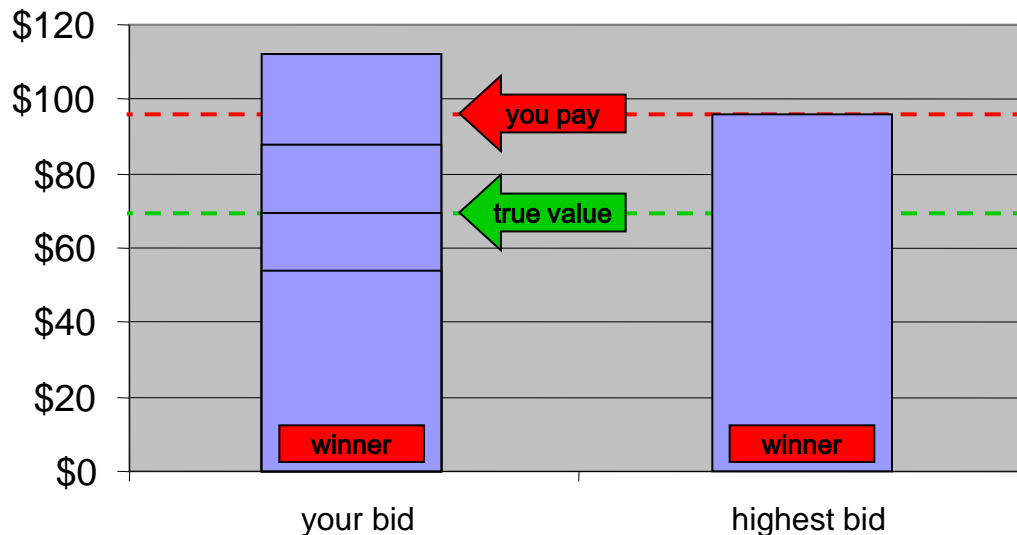

- bid **less**:
 - no difference (still lose, pay nothing)
- bid **more**:
 1. no difference
 2. you win, pay too much



Help

Browse help

▶ [Searching & researching](#)

▼ [Bidding & buying](#)

[Buying basics](#)

[All about bidding](#)

[Managing your buying activity](#)

[Resolving buying problems](#)

[Becoming a better buyer](#)

▶ [Selling & seller fees](#)

▶ [Payment & shipping](#)

▶ [Feedback](#)

▶ [Membership & account](#)

[eBay glossary](#)

[eBay acronyms](#)

[A-Z index](#)

Automatic bidding

Our automatic bidding system makes bidding convenient so you don't have to keep coming back to re-bid every time someone places another bid.

How automatic bidding works

- ✔ When you place a bid, you enter the maximum amount you're willing to pay for the item. The seller and other bidders don't know your maximum bid.
- ✔ We'll place bids on your behalf using the automatic [bid increment](#) amount, which is based on the current high bid. We'll bid only as much as necessary to make sure that you remain the high bidder, or to meet the reserve price, up to your maximum amount.
- ✔ If another bidder places the same maximum bid or higher, we'll notify you so you can place another bid. Your maximum bid is kept confidential until it is exceeded by another bidder.

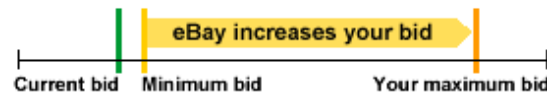

Here's an example:

1. The current bid for an item is \$10.00. Tom is the high bidder, and has placed a maximum bid of \$12.00 on the item. His maximum bid is kept confidential from other members.
2. Laura views the item and places a maximum bid of \$15.00. Laura becomes the high bidder.
3. Tom's bid is raised to his maximum of \$12.00. Laura's bid is now \$12.50.
4. We send Tom an email that he has been outbid. If he doesn't raise his maximum bid, Laura wins the item.

Contact us

Have a question? We can help.

Ask eBay members

Get help from other eBay members. Visit the [Answer Center](#) to post a question.

Related help topics

- [Reserve price listings](#)
- [Changing your maximum bid](#)
- [Getting outbid](#)
- [Bid increments](#)



MARKET DESIGN & ANALYSIS: ADVERTISING AUCTIONS

Discuss **why Google changed the rules of the market that is responsible for nearly all of its revenue**, how market design can help farmers in Uganda, and why algorithmic problems lie at the heart of the FCC's new, multi-billion dollar project to migrate the airwaves from broadcast TV to mobile telephony.



vancouver real estate

Web

Images

Maps

More ▾

Search tools

About 93,200,000 results (0.17 seconds)

Ads related to **vancouver real estate** ⓘ

Real Estate in Vancouver - Easy to Search MLS Listings

www.rew.ca/

Sign Up for a Free Property Alert!

Homes For Sale Vancouver - PropertiesSeach.ca

www.propertiesseach.ca/

Find All MLS Listed Homes for Sale Cheap Properties starting \$100,000

Ranking: descending by (quality score) x (bid amount)

quality score: click-through rate; (secret) measures of ad relevance

“The AdWords Discounter will charge you the **lowest CPC** you can be charged while still maintaining your position”

Estimate traffic for new keywords

Before adding keywords to search campaigns, use the Traffic Estimator to see how they could perform.

Targeting Locations: All Languages: English Networks: Google search

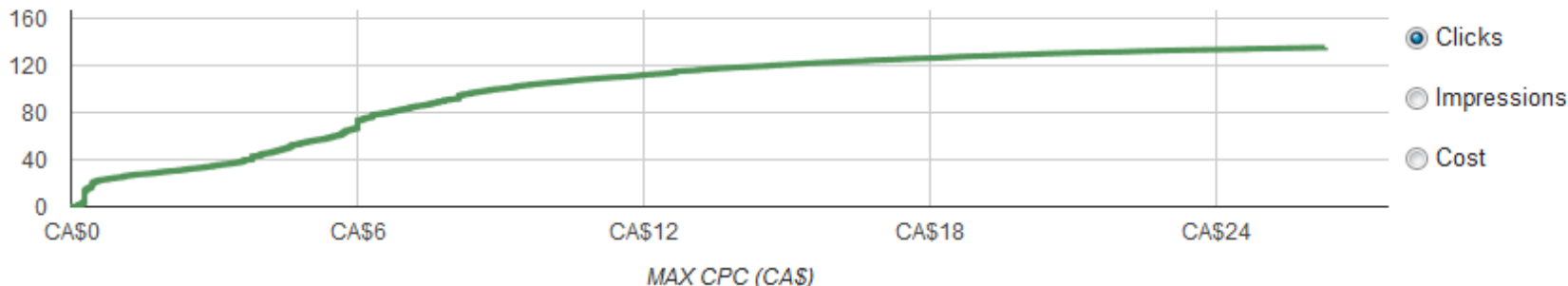

Daily estimates Max CPC CA\$ **10,000.00** Daily budget CA\$ 0.00

Total clicks ● 138 - 169	Total impressions 32,069 - 39,195	Average ad position 1.0 - 1.2	Total cost CA\$3,527.34 - CA\$4,311.20
-----------------------------	--------------------------------------	----------------------------------	---

+ Add keywords Edit Move Download + Add to account

	Draft campaign	Daily Clicks	Daily Impr.	Avg. Pos.	Daily Cost	CTR	Avg. CPC
	Draft campaign (1 ad groups, 4 keywords)	153.32	35,632	1.1	CA\$3,919.27	0.4%	CA\$25.56
	Different keywords I could bid on (4) edit	153.32	35,632	1.1	CA\$3,919.27	0.4%	CA\$25.56
	game theory	0.38	146	1	CA\$9.41	0.3%	CA\$24.51
	university of british columbia	4.41	950	1	CA\$152.07	0.5%	CA\$34.49
	vancouver real estate	44.65	7,954	1.1	CA\$858.41	0.6%	CA\$19.22
	computer science	103.87	26,580	1.1	CA\$2,899.38	0.4%	CA\$27.91

Analyzing Ad Auctions

- Search engines used **different auctions** over the years
 - GFP: Yahoo! and Overture 1997-2002
 - uGSP: Yahoo! 2002-2007
 - wGSP: Google, Microsoft, Yahoo! 2007-present

Question: Is wGSP better than GFP and uGSP?

- Better by **what metric:**
 - revenue?
 - efficiency?

Computational Mechanism Analysis

- What happens **in equilibrium of real-world mechanisms**, under given valuation distributions?
 - go **beyond theoretical analysis** of mechanism properties
 - answer **quantitative questions** (e.g., “which gives higher revenue?”)
 - gives answers even in **complex domains**
(reserve prices; messy valuation distributions; general eqm concepts)
- How it works:
 - repeatedly **sample games** from the valuation distribution
 - represent these games as **AGGs**
 - **solve them** using general AGG solvers
 - obtain statistics on **economic quantities** of interest

Analyzing Ad Auctions: Efficiency

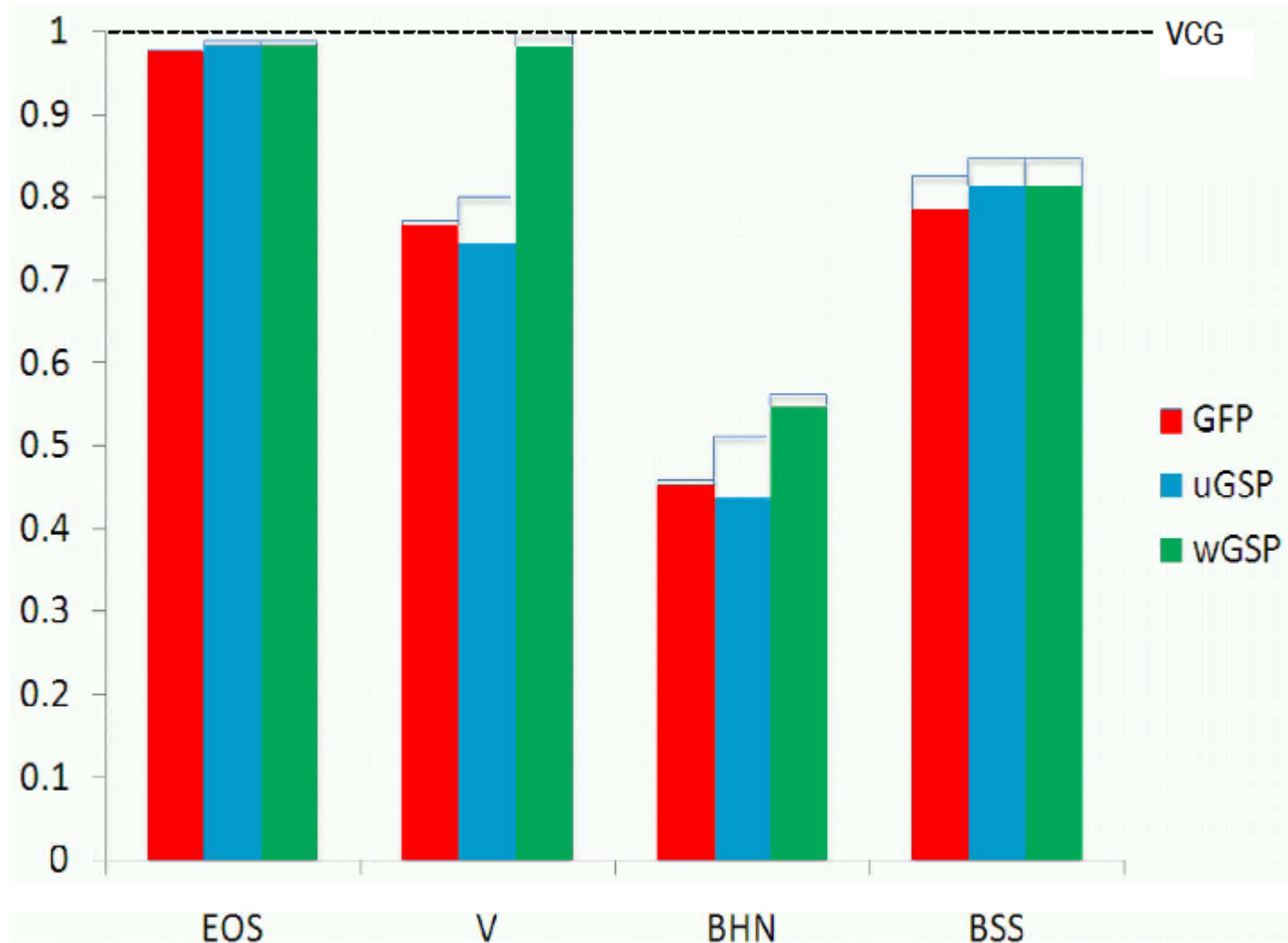

Analyzing Ad Auctions: Revenue

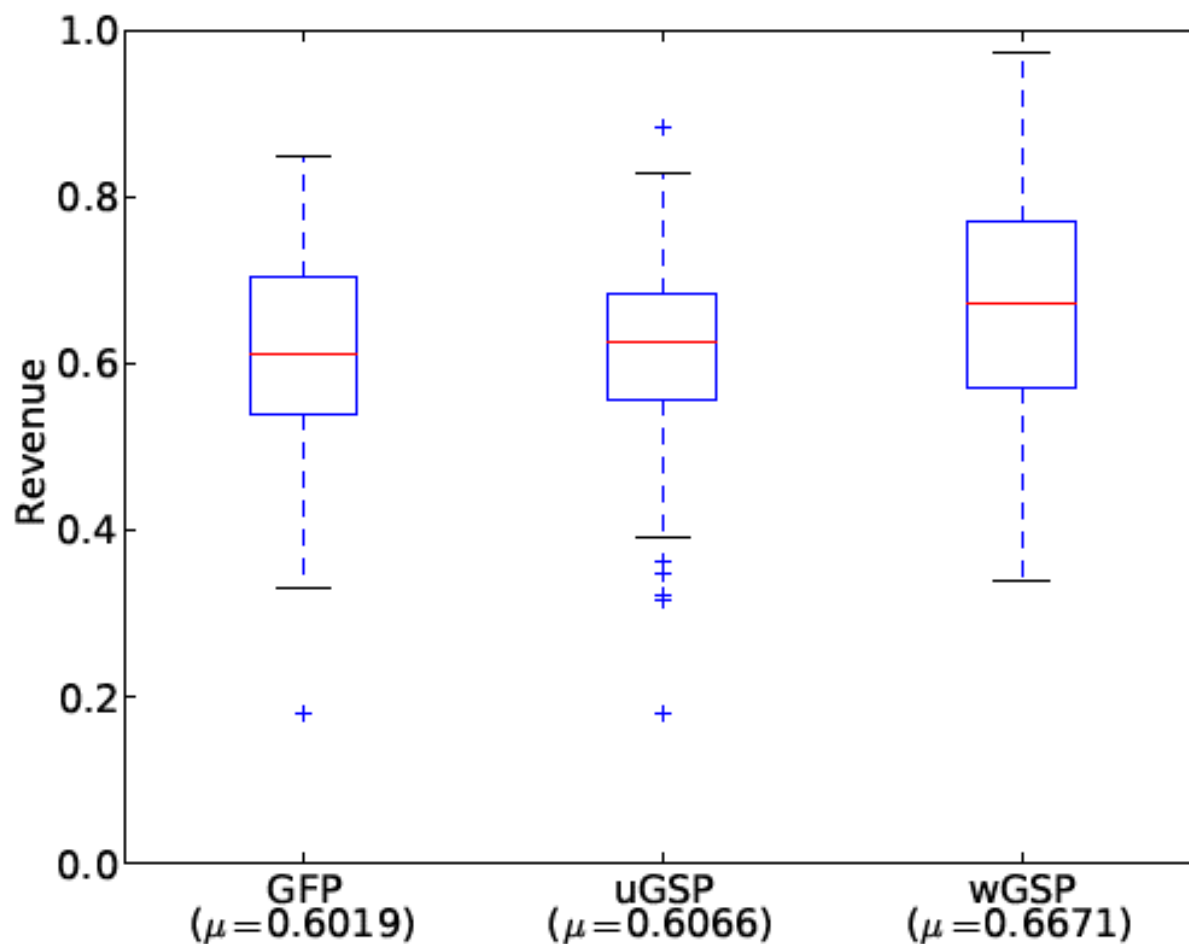

Analyzing Ad Auctions: Revenue

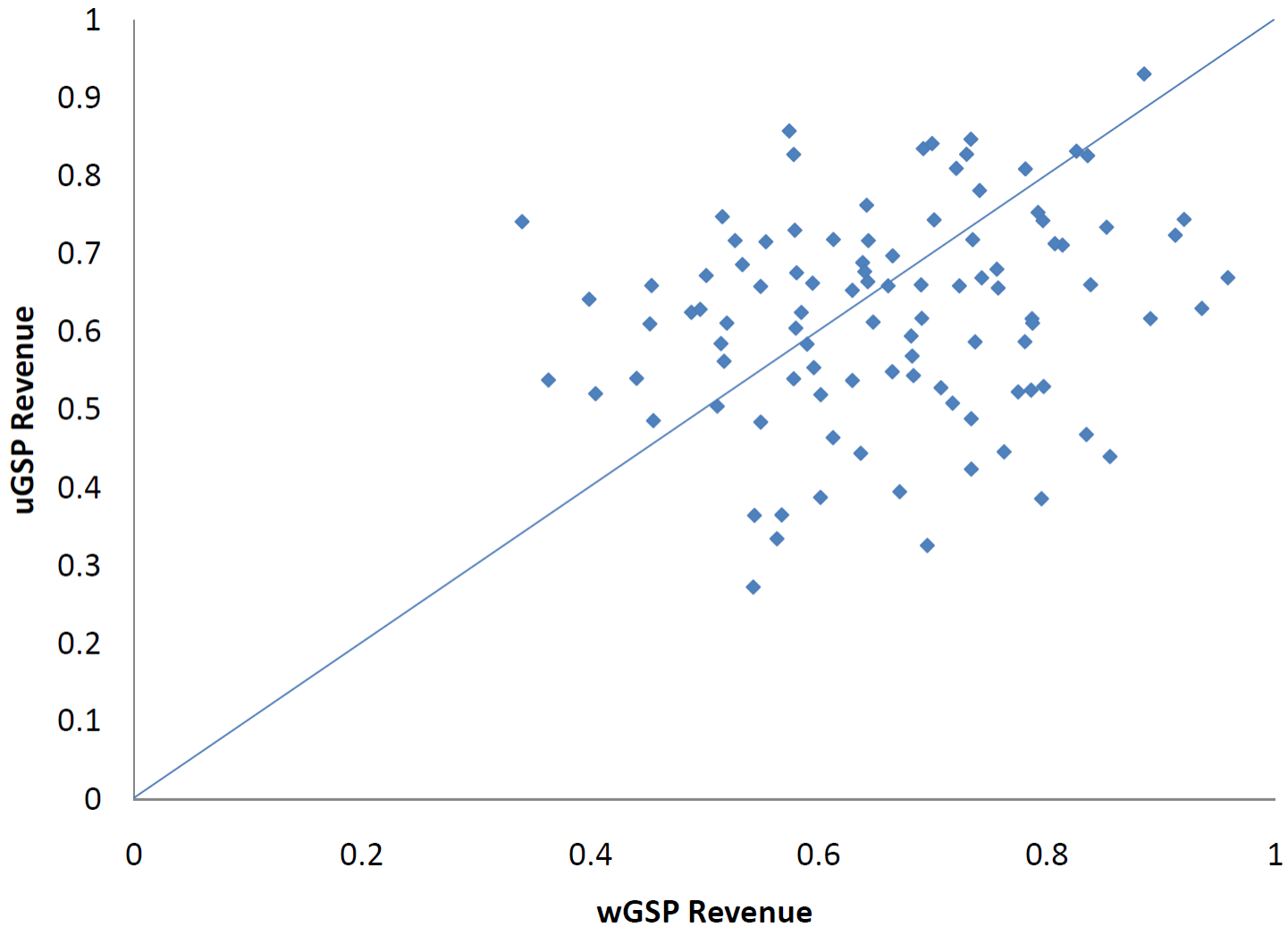



MARKET DESIGN & ANALYSIS: KUDU

Discuss why Google changed the rules of the market that is responsible for nearly all of its revenue, **how market design can help farmers in Uganda**, and why algorithmic problems lie at the heart of the FCC's new, multi-billion dollar project to migrate the airwaves from broadcast TV to mobile telephony.

African produce market circa 1900



Ugandan produce market circa 2011



Sometimes the scale is a bit bigger...



Sometimes the scale is a *lot* bigger...



Problem: Market Inefficiency

- **Subsistence agriculture** is the main occupation in Uganda
- Farmers **waste a lot of time** transporting produce; waiting by the road
- Buyers and sellers have trouble **finding each other**
- Sporadic **food shortages** in urban centers
- Robust **arbitrage** opportunities

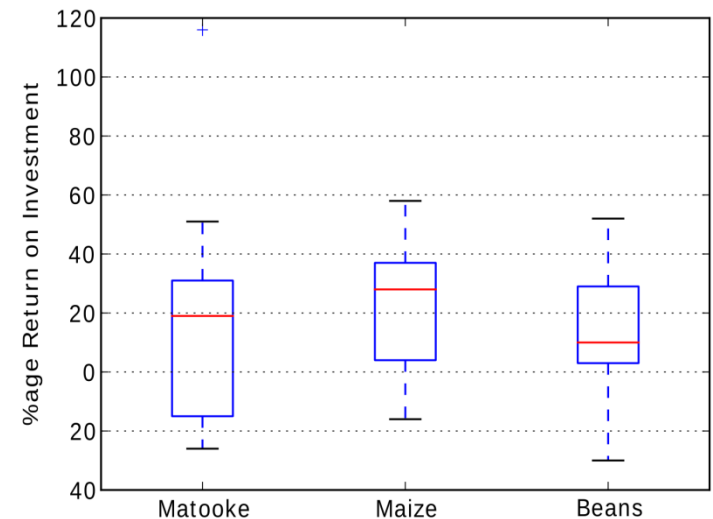

The wave of the future?



Kudu: an SMS-based market for agricultural commodities

- **bids** consider price, reputation, quality, geographic location
- **market** clears daily
 - posted prices for farmers
 - second-pricing for buyers
- can **ban** specific traders

Prototype is **up and running!**

- <http://www.kudu.ug>

Kudu trade

Welcome to Kudu! Buy and sell agricultural goods in Uganda with our easy-to-use auction system.

[How to buy »](#)
[How to sell »](#)
[Create Account](#)

Existing users please log in

Phone number:

Passcode:

[Login](#)

Kudu stats

(as of March 18, 2013)

Current number of traders: 506

Current top 5 products among buyers, and total quantities offered:

Maize (Kasooli)	157705 Kgs
Beans (Nambale)	28825 Kgs
Coffee (Kibooko)	14280 Kgs
Coffee (Robusta)	10900 Kgs
Cassava (Muwogo)	5000 Kgs

Current top 5 products among sellers, and total quantities bid for:

Maize (Kasooli)	480000 Kgs
Simsim (Ntungo)	105000 Kgs
Matooke	81100 Bunches
Beans (Nambale)	71250 Kgs
Coffee (Coronal-Endokwa)	20000 Kgs

Number of registered Kudu users

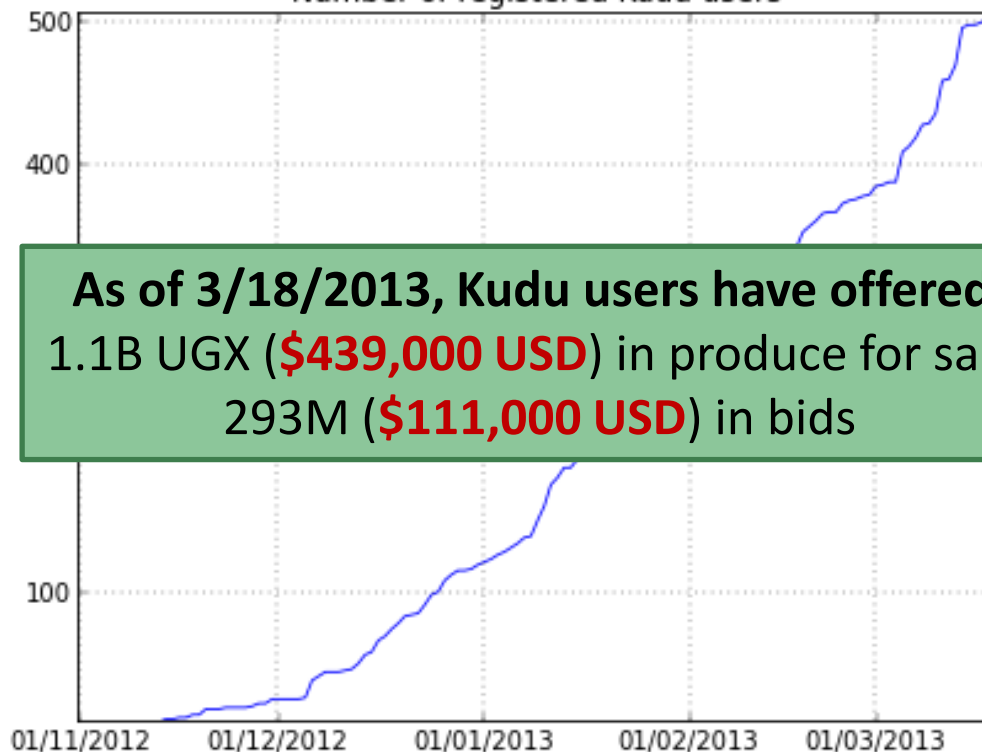



MARKET DESIGN & ANALYSIS

SPECTRUM REPACKING

Discuss why Google changed the rules of the market that is responsible for nearly all of its revenue, how market design can help farmers in Uganda, and **why algorithmic problems lie at the heart of the FCC's new, multi-billion dollar project to migrate the airwaves from broadcast TV to mobile telephony.**

WORLD

U.S.

N.Y. / REGION

BUSINESS

TECHNOLOGY

SCIENCE

HEALTH

SPORTS

OPINION

F.C.C. Backs Proposal to Realign Airwaves





By EDWARD WYATT

Published: September 28, 2012

WASHINGTON — The government took a big step on Friday to aid the creation of new high-speed wireless Internet networks that could fuel the development of the next generation of smartphones and tablets, and devices that haven't even been thought of yet.

The five-member [Federal Communications Commission](#) unanimously approved a sweeping, though preliminary, proposal to reclaim public airwaves now used for broadcast television and auction them off for use in wireless broadband networks, with a portion of the proceeds paid to the broadcasters.

The initiative, which the F.C.C. said would be the first in which any government would pay to reclaim public airwaves with the intention of selling them, would help satisfy what many industry experts say is booming demand for wireless Internet capacity.

 FACEBOOK TWITTER GOOGLE+ E-MAIL SHARE PRINT REPRINTS

The FCC's "Incentive Auction"

- **Forward (ascending-price) auction** for telecom firms
 - prices in each region increase as long as demand exceeds supply
- **Reverse (descending-price) auction** for broadcasters
 - stations declare they're willing to stop broadcasting at a given, initially high, price
 - price descends as long as stations can feasibly be "repacked" into the reduced amount of spectrum, given interference constraints
 - **the better this repacking works, the less the government pays**
- Quantity reallocated may depend on prices offered

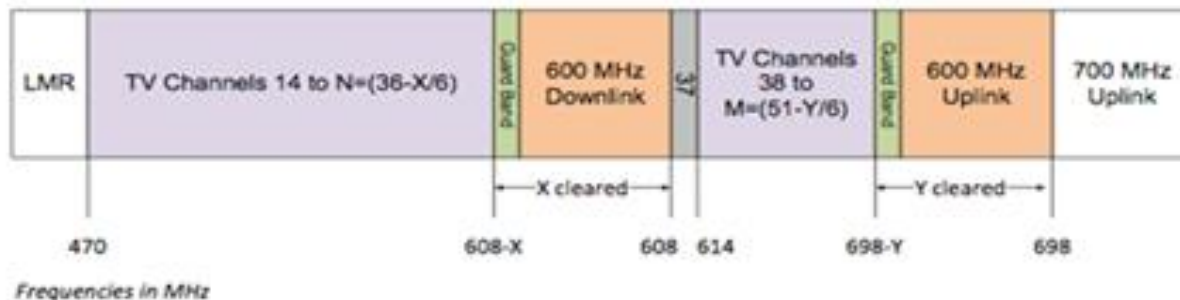

Feasibility Testing

Key computational problem: testing the feasibility of a given repacking, based on interference constraints

- A hard graph-colouring problem
 - The FCC believed that this problem couldn't be solved exactly at a national scale
- We're attacking it using tools from **empirical algorithmics**:
 - SAT encoding
 - automatic algorithm configuration
 - algorithm portfolios

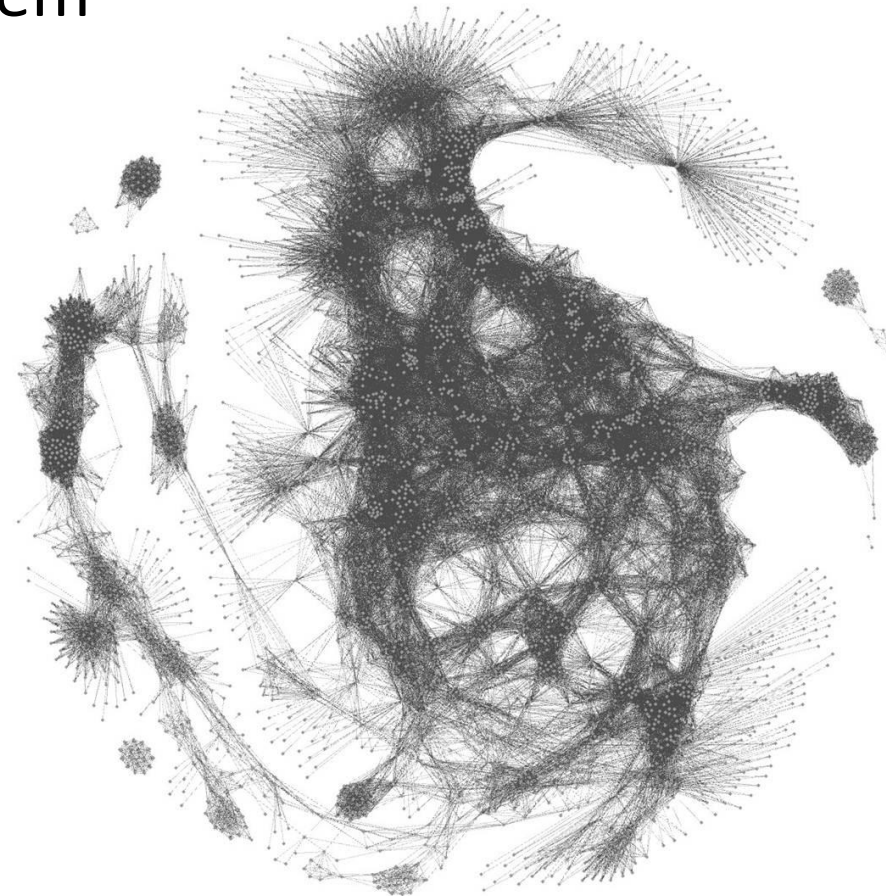

Initial Results

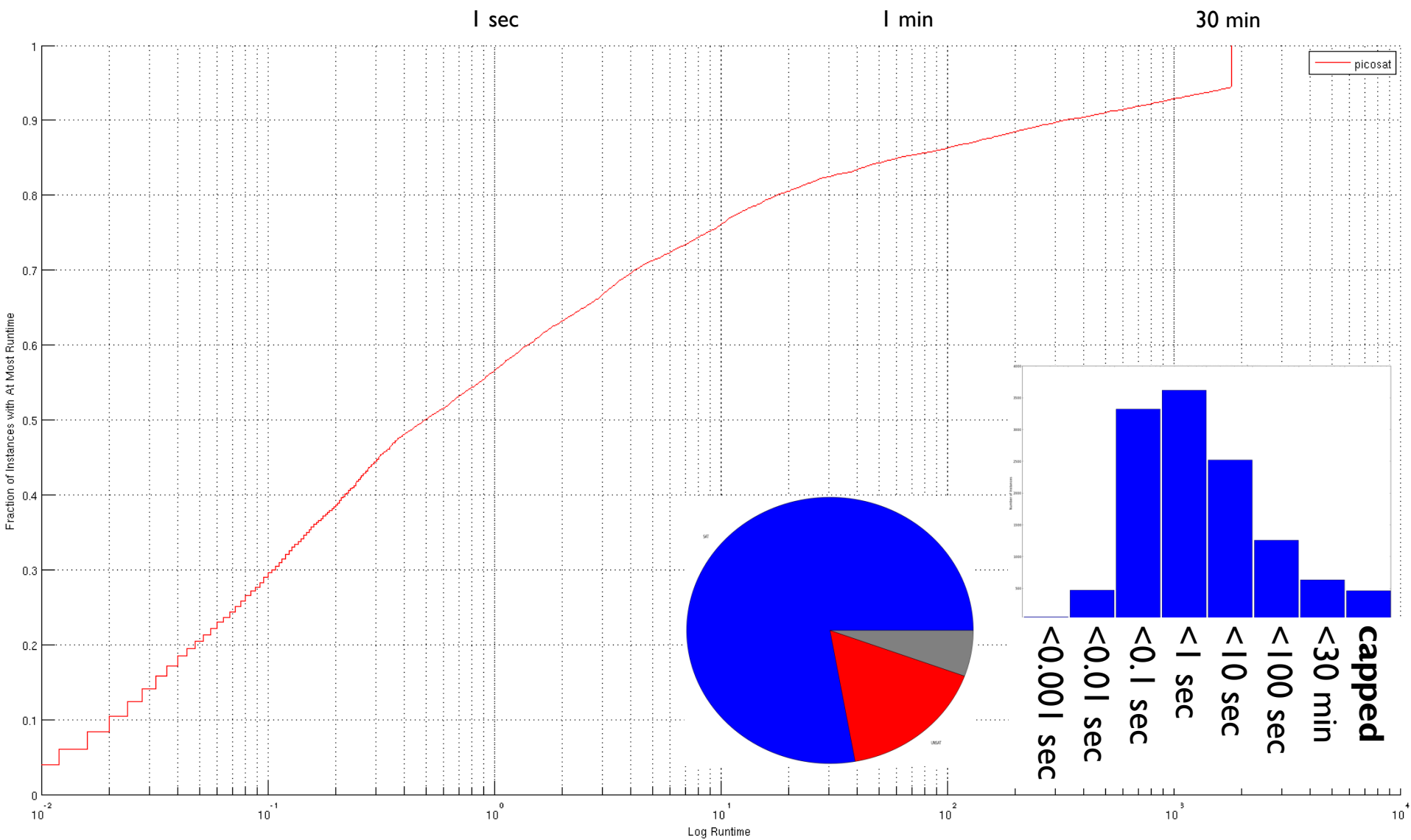

Initial Results

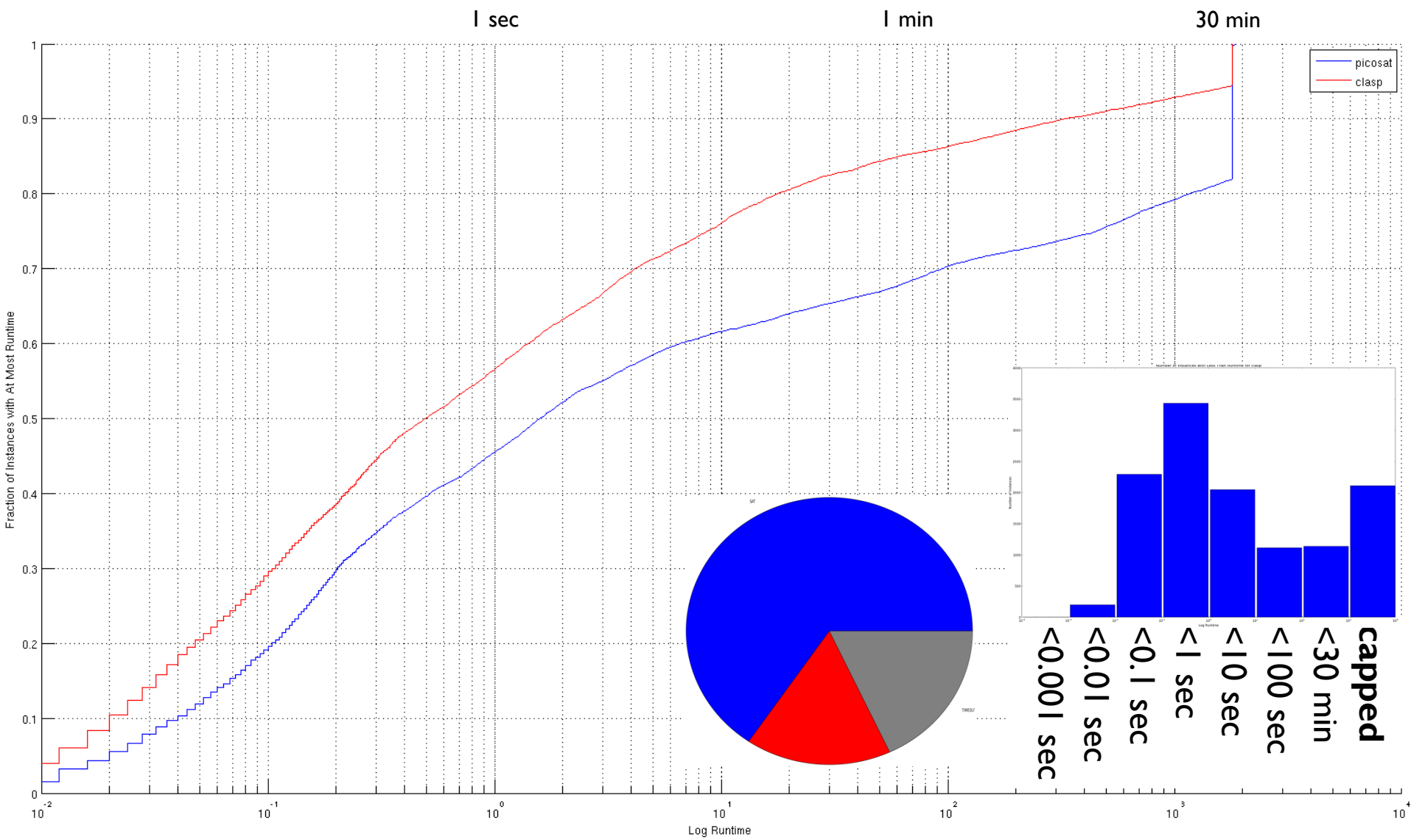

Automatic Configuration

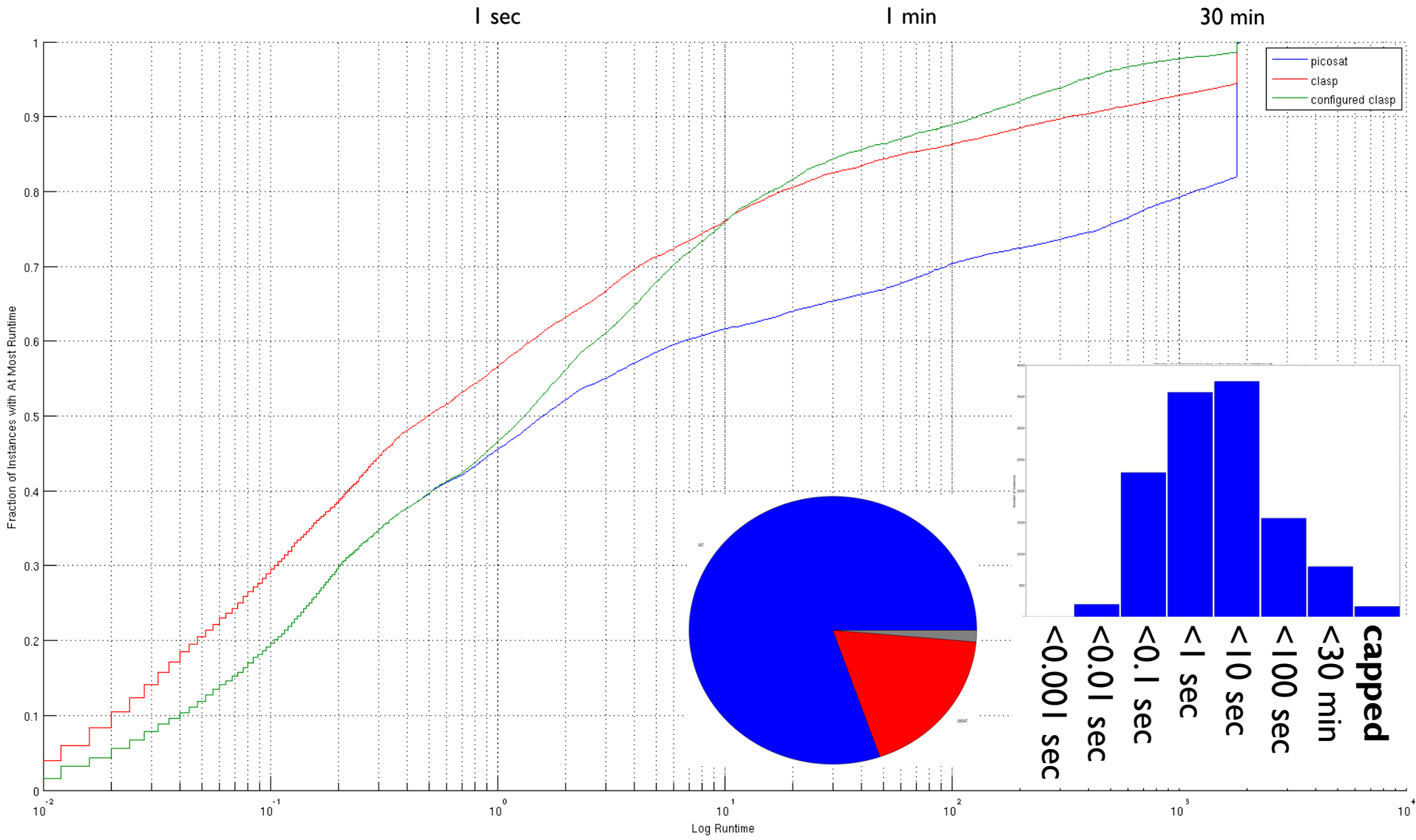



BEHAVIORAL GAME THEORY

Investigate how people actually reason in strategic situations, and how game theory can be extended to describe realistic, rather than idealized, behaviour.

Behavioural Game Theory

- Game theory offers a beautiful model of how **rational agents** would behave in strategic settings
 - BUT: people aren't rational!
 - What should we **expect people to do**?
 - for some settings, GT models are very accurate
 - in others, the GT prediction is wildly and robustly wrong
- **Behavioral game theory** models human behavior.
 - Challenge: many models, rarely compared
 - Our work:
 - first large-scale comparison
 - new analysis techniques
 - new models

Quantal Response [McKelvey & Palfrey, 1995]

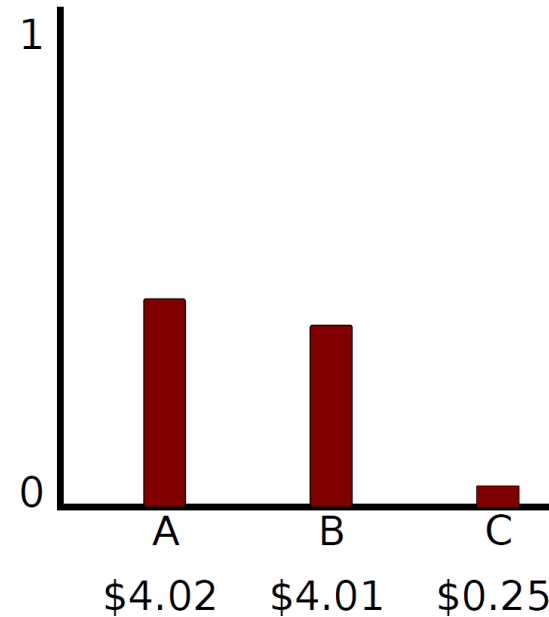
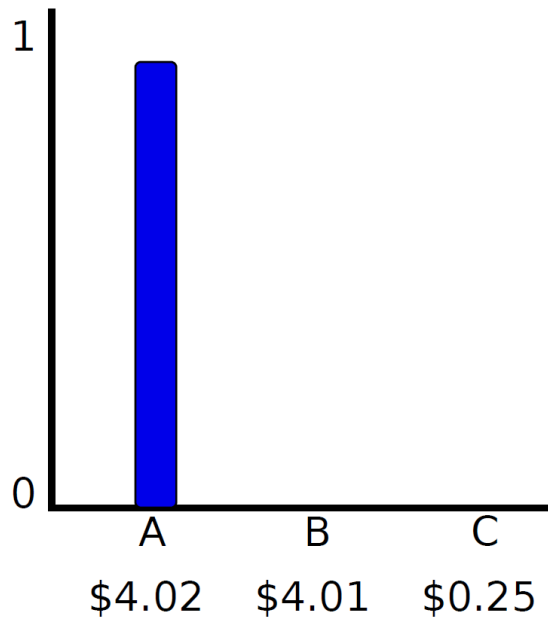

- **Best response:** always take the maximum-utility action
- **Quantal response:** take high-utility actions often; low-utility actions rarely

Iterative Reasoning

[Stahl & Wilson, 1994; Nagel, 1995; Camerer et al, 2004]

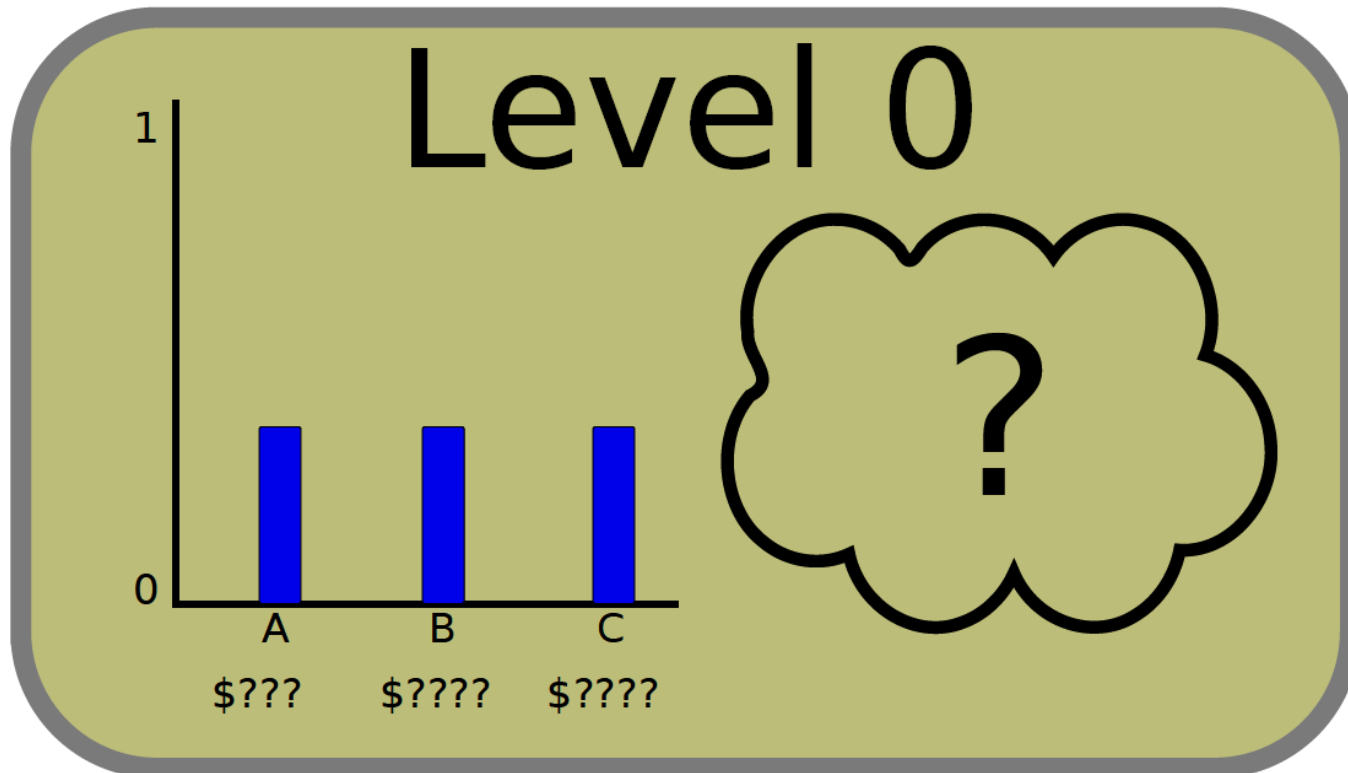

- Level 0 agents **don't reason about other agents**
 - so, let's say they **uniformly randomize** over their own actions

Iterative Reasoning

[Stahl & Wilson, 1994; Nagel, 1995; Camerer et al, 2004]

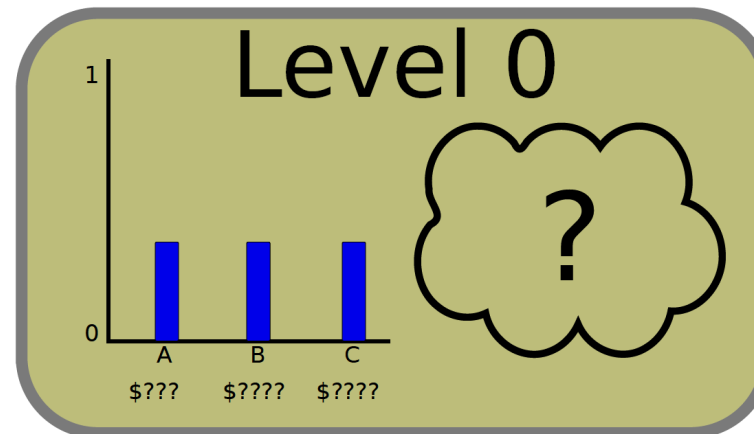
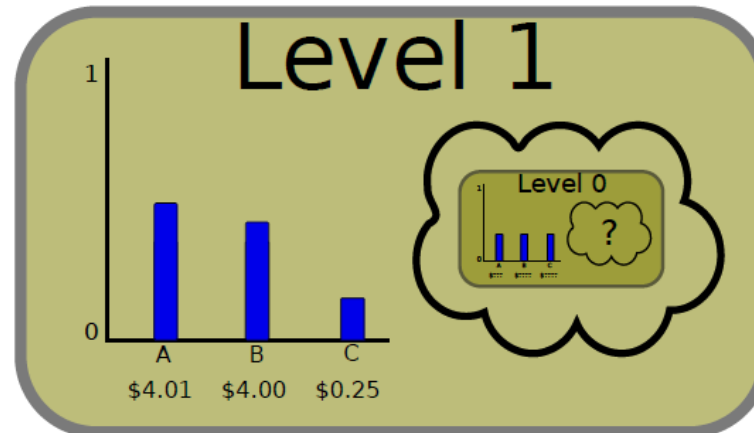

- Level 1 agents **believe everyone else is level 0**

Iterative Reasoning

[Stahl & Wilson, 1994; Nagel, 1995; Camerer et al, 2004]

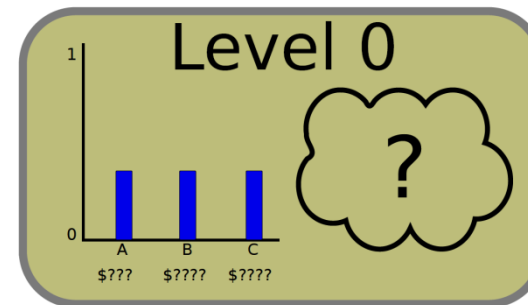
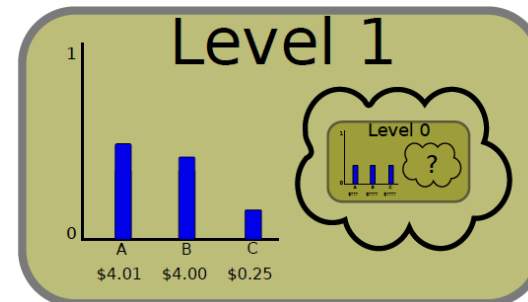
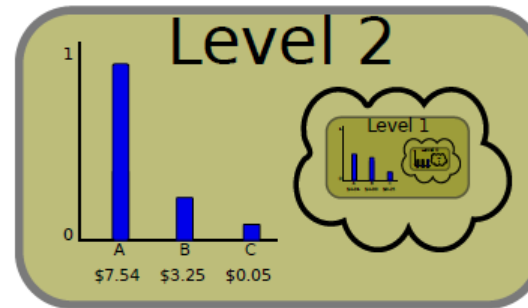

- Level 2 agents **believe everyone else is level 1** (or 0)

Key Findings of Our Work

- **Both modeling ideas** are helpful
 - best (and oldest!) model captures both
- Bayesian **parameter analysis**:
 - these models behave counterintuitively
 - model performance can be improved while also reducing number of params
- Modeling **salience** in level-0 yields dramatically better models
 - outcomes leading to best payoffs; good worst case; round numbers; top left...

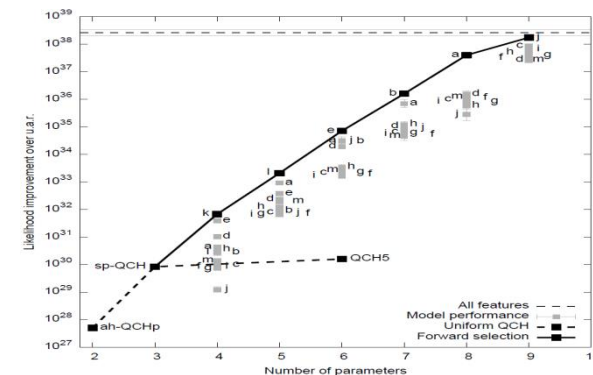
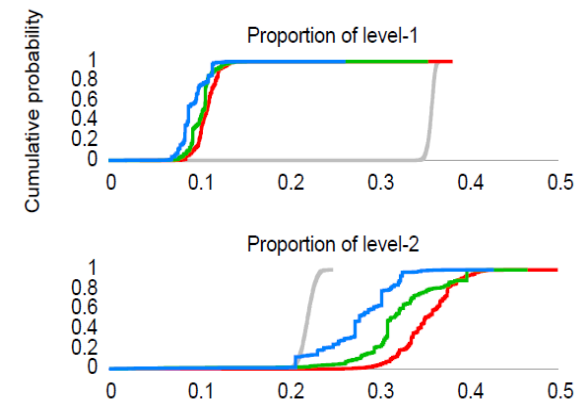
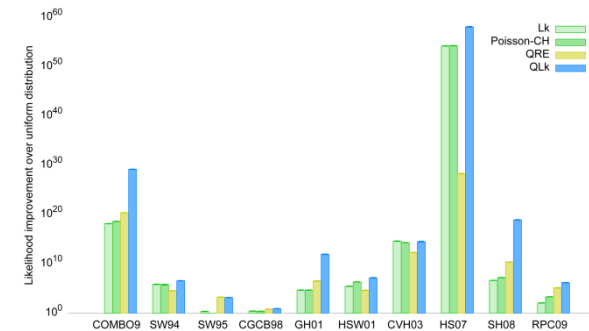

Reasoning about an Interconnected World

- **Reasoning about Large Games:** can compute equilibria (etc.) of large game-theoretic interactions by representing them as action-graph games
- **Market Design & Analysis:** game theory can be leveraged to construct protocols that work even if agents aren't cooperative
 - **Advertising auctions:** computational techniques help to explain the evolution of rules in markets like Google's AdWords have evolved
 - **Kudu:** an SMS-based market for agricultural commodities in Uganda
 - **Spectrum repacking:** computational issues are at the heart of the FCC's upcoming radio spectrum redistribution
- **Human Strategic Behaviour** is predictable; we're making progress on building models that anticipate how people will act

Thanks to my collaborators!

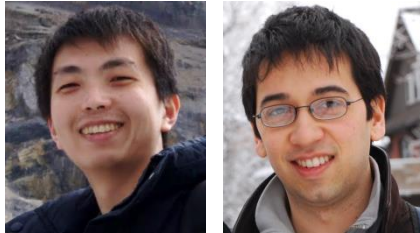

- **Albert Xin Jiang, Navin Bhat**
– *AGGs*



- **David R.M. Thompson**
– *Ad auctions*



- **John Quinn, Richard Ssekibuule**
– *Kudu*

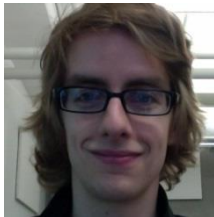

- **Alexandre Fréchette**
– *Spectrum repacking*



- **James R. Wright, Colin Camerer**
– *Behavioral game theory*